

RT16(NT)

系列有填料封闭管式刀型触头熔断器



一、适用范围

RT16(NT)系列低压熔断器具有体积小、重量轻、分断能力高等特点，广泛用于电气设备的过载保护和短路保护。

产品符合GB/T13539.1 GB/T13539.2标准。

二、型号及含义

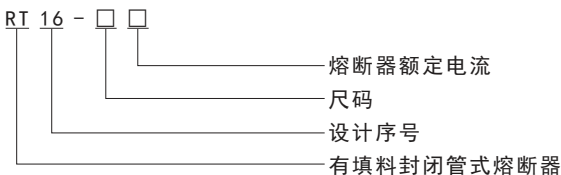

三、主要技术参数

熔断器额定分断能力：500V：COSΦ0.1~0.2为120KA；660V：COSΦ0.1~0.2为50KA。

尺码	额定电流(A)	额定电压(V)		额定功率(KW)	重量(Kg)
1	80	380 500	660	6.20	0.36
	100			7.50	
	125			10.2	
	160			13.0	
	200			15.2	
	224			16.8	
	250			18.3	
2	125	380 500	660	9.00	0.65
	160			11.5	
	200			15.0	
	224			16.0	
	250			18.4	
	300			21.0	
	315			19.2	
	355			24.5	
	400			26.0	
3	315	380 500	660	27.1	0.85
	355			22.7	
	400			26.8	
	425			28.9	
	500			32	
	630			40.3	
4	800	500 660		90	1.2
	1000				
0	4	500 660		1.03	0.2
	6			1.42	
	10			2.45	
	20			2.36	
	25			2.70	
	32			3.74	
	36			4.30	
	40			4.70	

A 一级配电
Primary power distribution

B 二级配电
Secondary distribution

C 终端配电
Terminal power distribution

D 工业控制与保护
Industrial control and protection

E 电源电器
power device

F 电能管理
Power management

G 高压元件
High voltage components

RT16(NT)

系列有填料封闭管式刀型触头熔断器

尺码	额定电流(A)	额定电压(V)	额定功率(KW)	重量(Kg)
0	50	500 660	5.50	0.2
	63		6.90	
	80		7.60	
	100		8.90	
	125		10.1	
	160		15.2	
00C	4	380 500	0.67	0.12
	6		0.89	
	10		1.14	
	16		1.65	
	20		1.94	
	25		2.50	
	32		3.32	
	36		3.56	
	40		4.30	
	50		4.50	
	63		4.60	
	80		6.00	
	100		7.30	
	00		4	
6		0.89		
10		1.14		
16		1.65		
20		1.94		
25		2.50		
32		3.32		
36		3.56		
40		4.30		
50		4.50		
63		4.60		
80		6.00		
100		7.30		
		125	7.80	
	160	9.60		

四、外形及安装尺寸

1、熔断体尺寸图

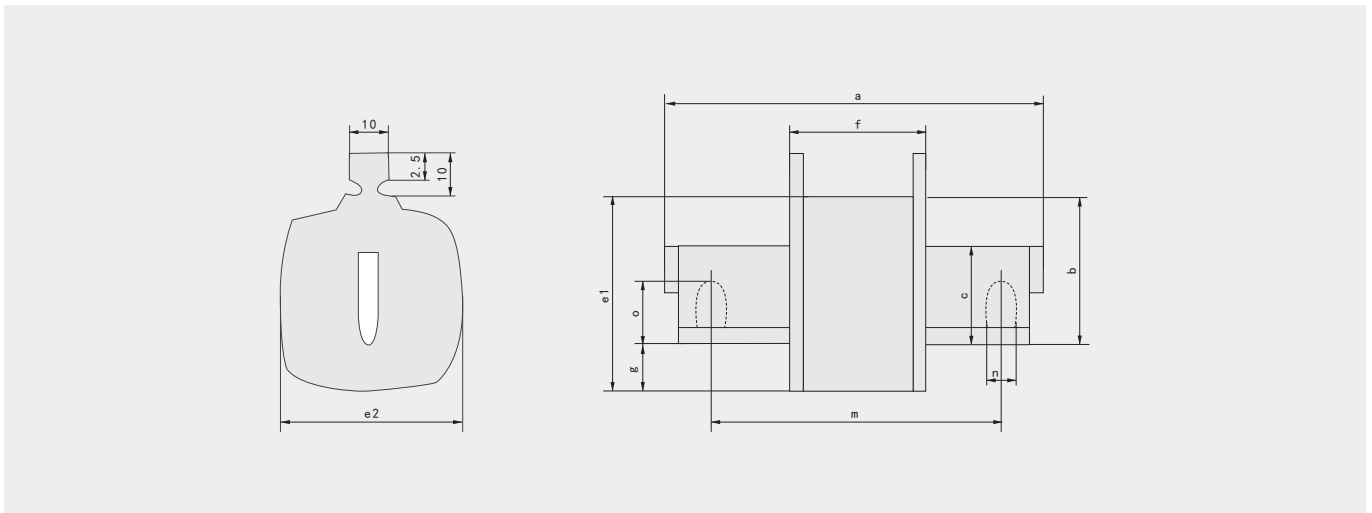

RT16(NT)

系列有填料封闭管式刀型触头熔断器

尺码	00C	00	0	1	2	3	4
a	78.5	78.5	126	135	150	150	200
b	35	35	35	40	48	60	75
c	15	15	15	21	27	33	50
e1	45	45	45	48	58	67	95
e2	20	29	29	48	58	67	86
f	50	50	68	68	68	68	87
g	11.5	11.5	11.5	12	13	14.2	20
m							150
n							14
o							32

2、熔断体配用的熔断器底座尺寸图

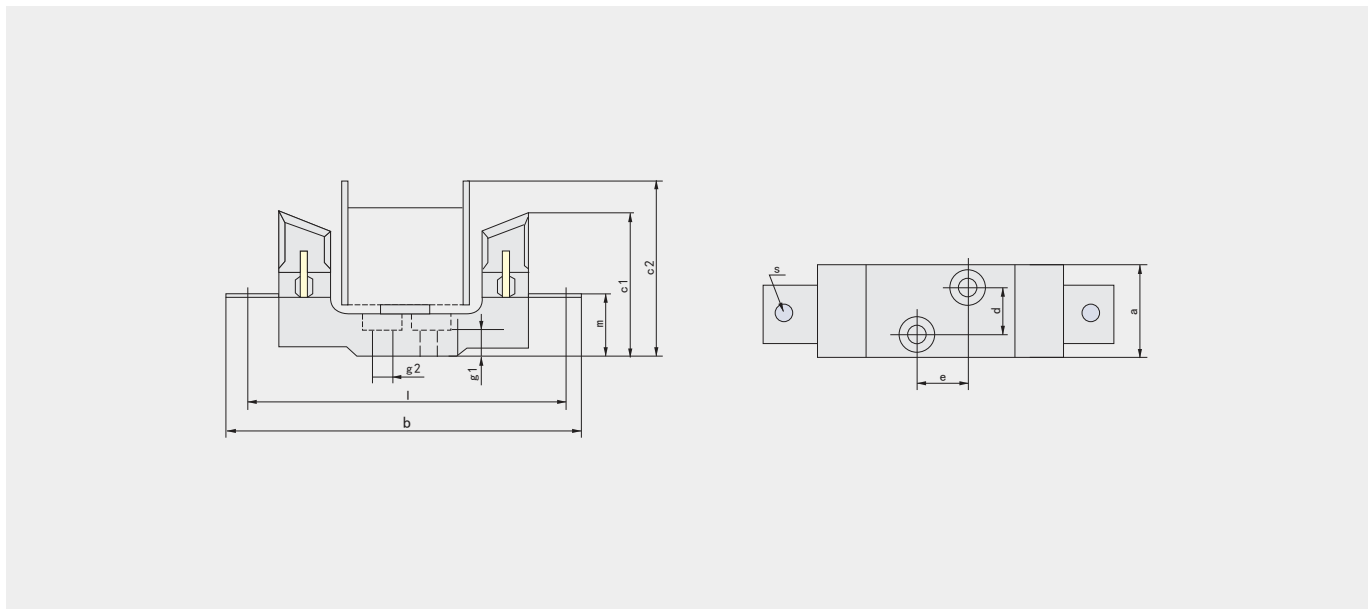

尺码	00	0	1	2	3	4
a	30	30	58	64	64	88
b	120	170	200	225	250	304
c1	60	73	82	98	105	143
c2	85	93	96	112	120	165
d	0	0	30	30	30	45
e	25	25	25	25	25	30
g1	8	16	15	17	17	11
g2	7.5	7.5	10.5	10.5	10.5	10.5
i	100	150	175	200	210	260
m	25	38	38	40	40.5	49
s	M5	M8	M10	M10	M10	M10