

# HH5□P

## 系列小型电磁继电器



### 一、适用范围

HH5□P 系列电磁继电器适用于电子控制设备、家用电器、办公自动化、试验测试、保安、商用机械、通讯设备、汽车、机床、建筑、运输设备、仪器仪表，可作为遥控中间转换或放大元件。交/直流规格齐全，安装方式多样；备有各种插座选用，并有带灯示灯的规格。

### 二、型号及含义

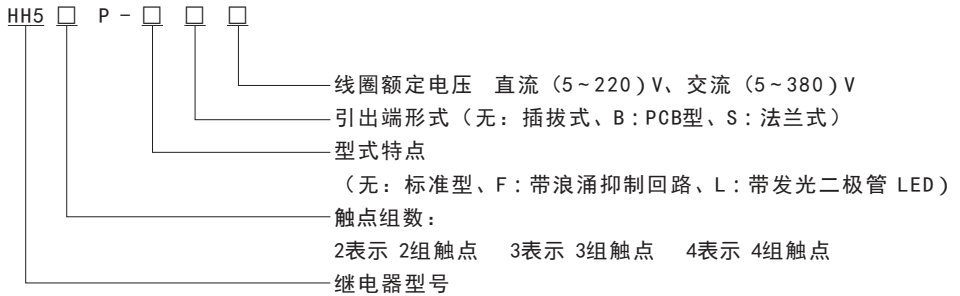

### 三、主要技术参数

触点	形式	2Z、3Z、4Z
	负载 (阻性)	5A/250VAC 30VDC
	接触电阻 (初始)	500mΩ
	材料	银合金
	电气寿命 (次)	1X10 <sup>5</sup>
	机械寿命 (次)	1X10 <sup>7</sup>
吸合电压		DC: ≤75%额定电压, AC: ≤80%额定电压
释放电压		DC: ≥10%额定电压, AC: ≥20%额定电压
最大电压		110%额定电压
线圈规格	直流 (DC)	5V、12V、24V、36V、48V、110V、127V、220V (电压可订制)
	交流 (AC)	5V、12V、24V、36V、48V、110V、127V、220V、380V (电压可订制)
线圈功率	直流 (DC)	0.9W
	交流 (AC)	1.2VA
吸合时间		≤25ms
释放时间		≤25ms
介质耐压	线圈轭铁间, 异组触点间	1500VAC
	断开触点间	1000VAC
绝缘电阻		≥100mΩ (500VDC)
环境温度		-25℃~+55℃
环境湿度		45%~75%RH
大气压力		86kPa~106kPa
冲击 (稳定性)		加速度100m/s <sup>2</sup> , 脉冲持续时间11ms
振动		双振幅1.0mm, 10~55Hz
安装方式		导轨插座式、螺栓安装式

# HH5□P

## 系列小型电磁继电器

### 四、配套插座

序号	继电器型号	插座型号
1	HH52P	PYF08A
2	HH53P	PYF11A
3	HH54P	PYF14A

### 五、外形及安装尺寸

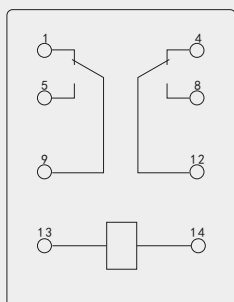

底视接线图 (2Z)

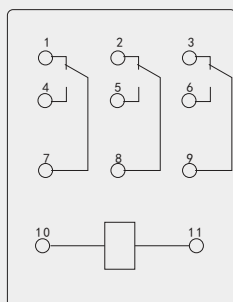

底视接线图 (3Z)

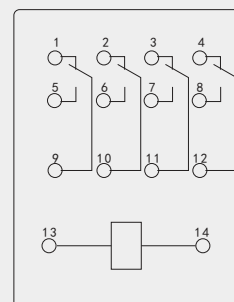

底视接线图 (4Z)

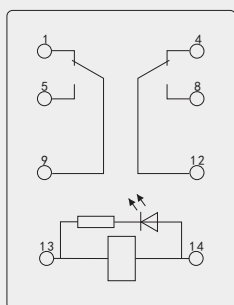

底视接线图 (2Z带指示灯)

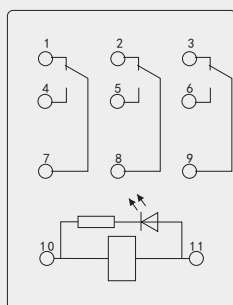

底视接线图 (3Z带指示灯)

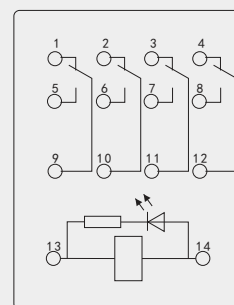

底视接线图 (4Z带指示灯)

**HH5□P**  
系列小型电磁继电器

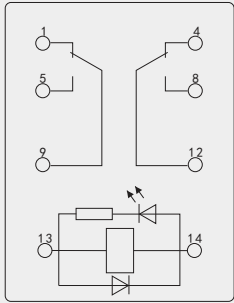

底视接线图 (2Z带指示灯及二极管)

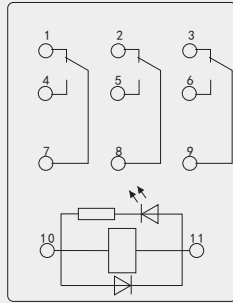

底视接线图 (3Z带指示灯及二极管)

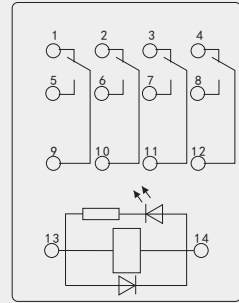

底视接线图 (4Z带指示灯及二极管)

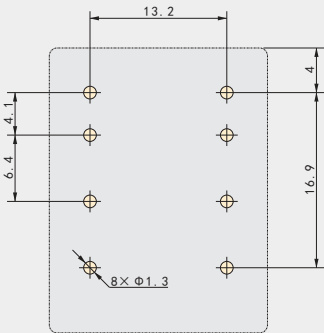

PCB安装孔位图 (2Z)

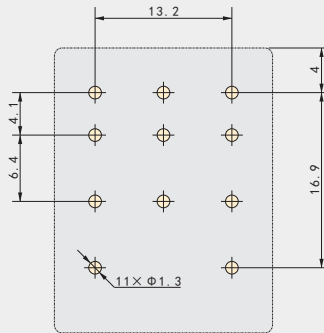

PCB安装孔位图 (3Z)

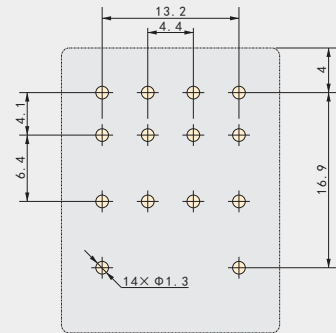

PCB安装孔位图 (4Z)

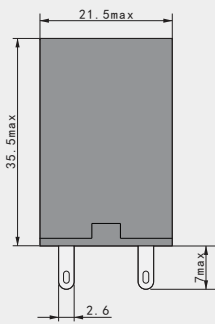

外形图 (2Z插拔式)

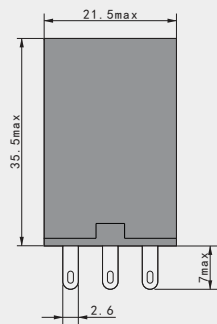

外形图 (3Z插拔式)

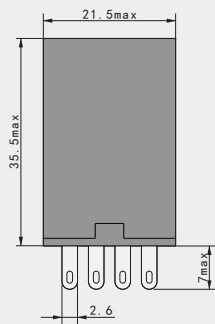

外形图 (4Z插拔式)

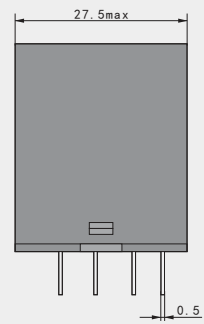

外形图左视图

**A** 一级配电  
Primary power distribution

**B** 二级配电  
Secondary distribution

**C** 终端配电  
Terminal power distribution

**D** 工业控制与保护  
Industrial control and protection

**E** 电源电器  
power device

**F** 电能管理  
Power management

**G** 高压元件  
High voltage components

**HH5□P**  
系列小型电磁继电器

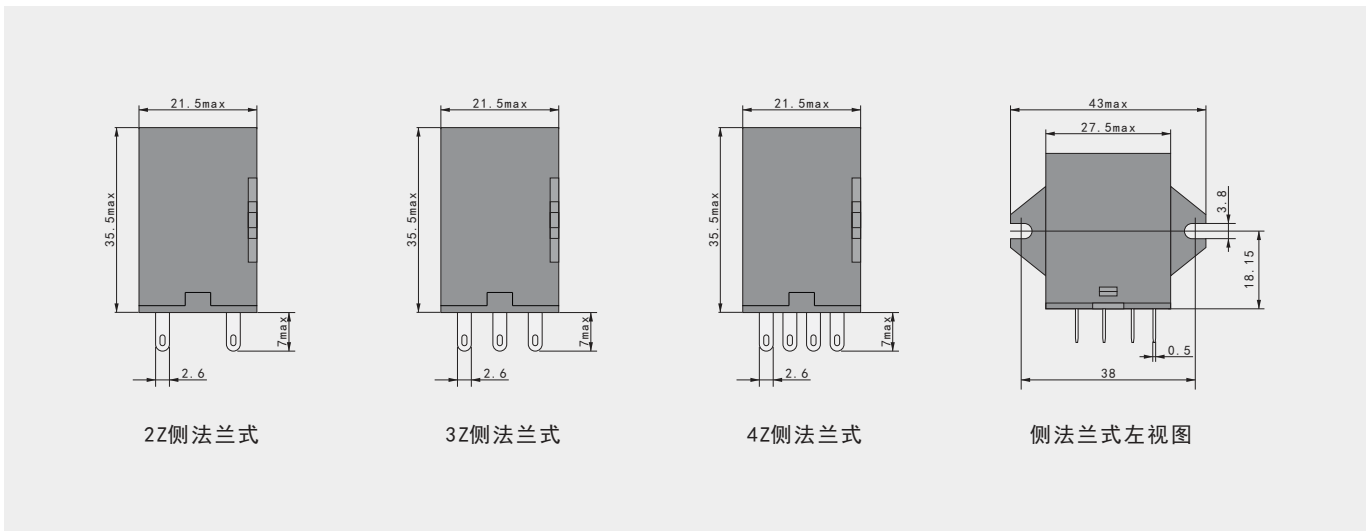
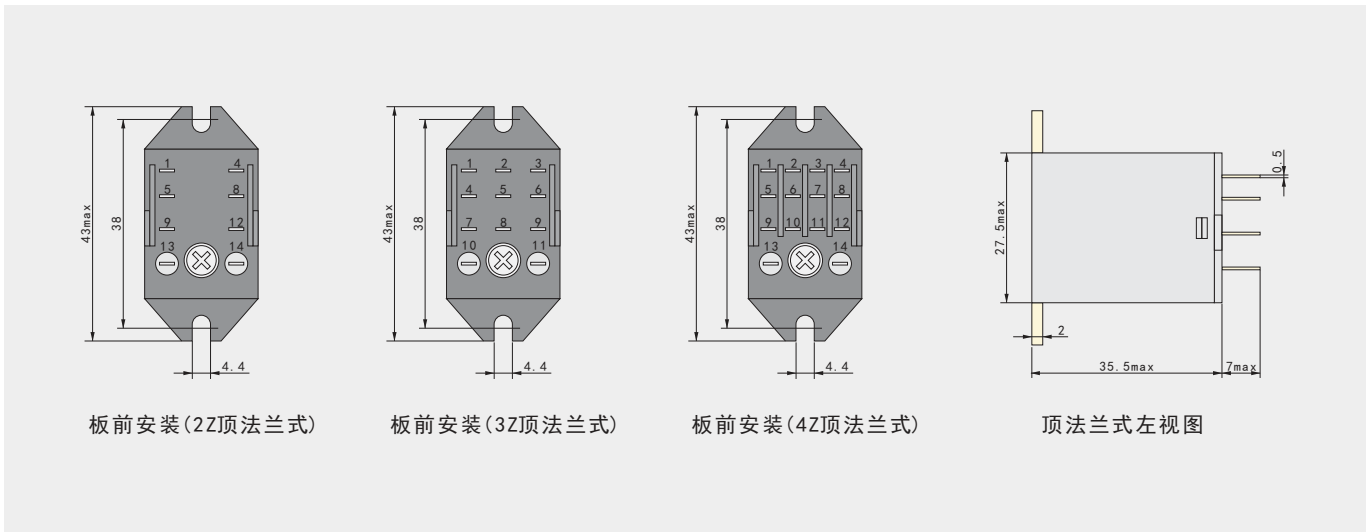
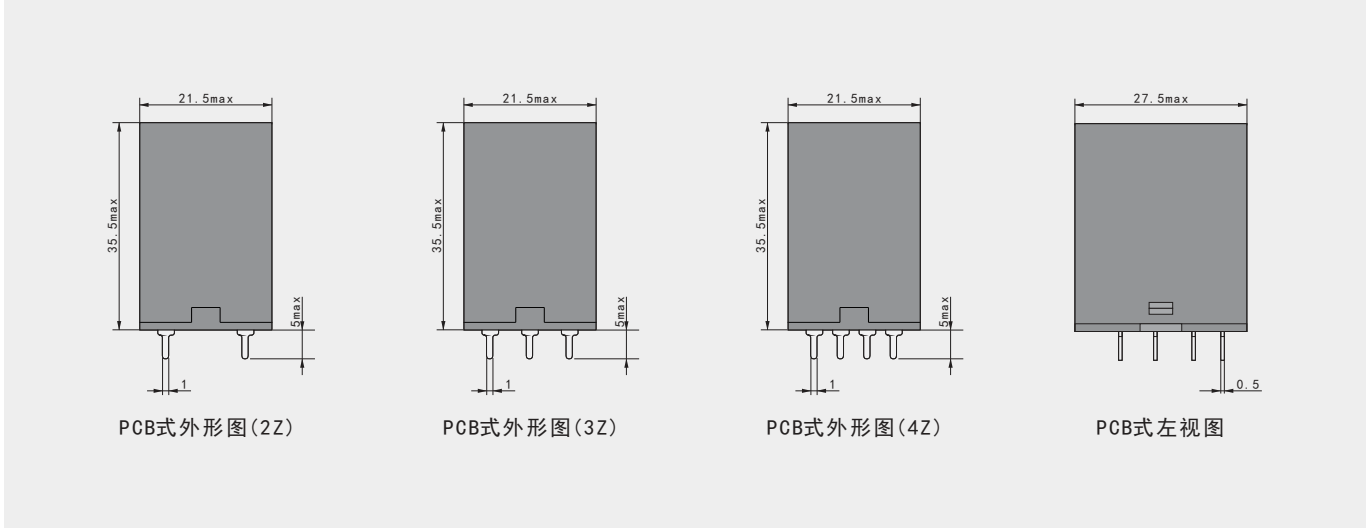

**HH5□P**  
系列小型电磁继电器

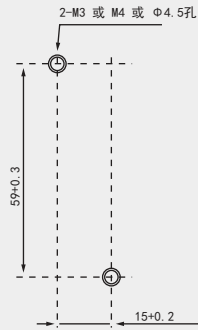
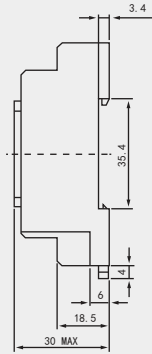
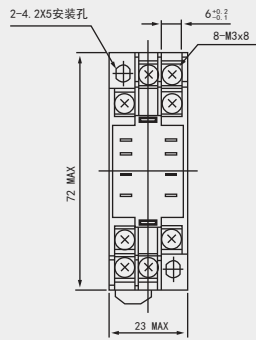

PYF 08A插座 (配 HH52P)

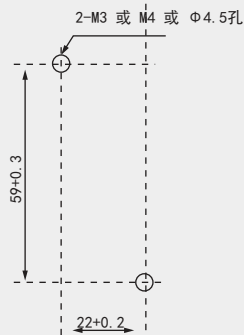
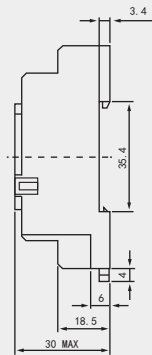
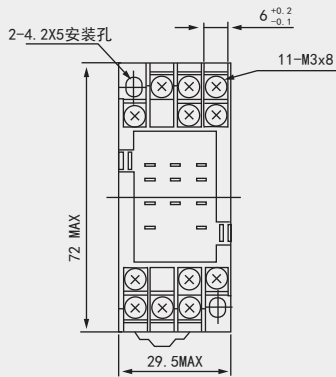

PYF 11A插座 (配 HH53P)

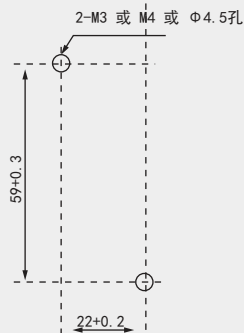
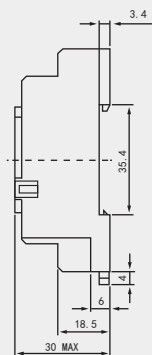
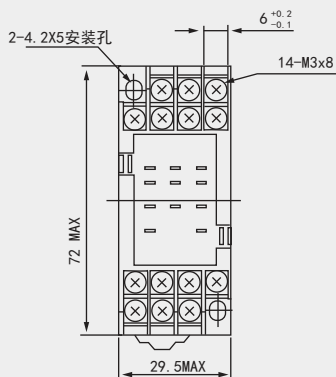

PYF 14A插座 (配 HH54P)

**A** 一级配电  
Primary power distribution

**B** 二级配电  
Secondary distribution

**C** 终端配电  
Terminal power distribution

**D** 工业控制与保护  
Industrial control and protection

**E** 电源电器  
power device

**F** 电能管理  
Power management

**G** 高压元件  
High voltage components